



Owner's Manual

Remote Controlled Dog Training Collars

dogtra 1800NC Series



Dogtra Company

22912 Lockness Avenue
Torrance, CA 90501 U.S.A.

Tel) 310.534.0101

Fax) 310.534.9111

Toll Free) 1.888.811.9111

Copyright © 2009 Dogtra Company All rights reserved.

2006- ④



www.dogtra.com

- MAIN FEATURES 2
- PRODUCT SAFETY AND HEALTH STATEMENTS 3
- **dogtra** COLLAR PACKAGE CONTENTS 5
- DESCRIPTION OF TRANSMITTER PARTS 6
- DESCRIPTION OF COLLAR / RECEIVER PARTS 16
- BATTERY CHARGER 21
- CHARGING THE BATTERIES 22
- TESTING YOUR **dogtra 1800NC SERIES** COLLAR 25
- OPERATING INSTRUCTIONS 27
- ACCESSORIES 31
- WARRANTY AND REPAIR INFORMATION 32

MAIN FEATURES

- Easy-to-use transmitter.
- All intensity level adjustments are made from a digital dial on the transmitter. There are 8 intensity levels. Level one is the lowest and level eight is the highest.
- Reliable stimulation effective for all types of dogs - no matter how heavy the coat.
- The ***dogtra 1800NC SERIES*** has a one-mile range.
- Waterproof collar receiver and transmitter.
- No external antenna on the collar receiver.
- Rechargeable, user - replaceable Ni-MH batteries.
- Over 3000 different identity codes to prevent conflicts with other collars.

PRODUCT SAFETY AND HEALTH STATEMENTS

Safety for your dog

Studies conducted by animal health professionals at Dogtra Company's training facilities showed no adverse effects to the cardiovascular or nervous system of dogs from e-collar stimulation. These studies involved healthy dogs in a controlled environment.

Dogs should be in good health during any e-collar training. Dogtra e-collars are not intended for use on dogs weighing less than 12 pounds or under 6 months of age.

Skin irritation can occur from prolonged wearing of the stainless steel contact points on the training collar. Most dogs will exhibit some type of irritation (pressure necrosis) from prolonged contact of stainless steel contact points. This is why it states in your owner's manual:

Attention:

Avoid having the dog wear the collar with the contact points in the same place for more than two hours at a time. Leaving the contact points on the same spot for an extended period of time can cause skin irritation. If the dog is to wear the e-collar for long periods, occasionally reposition the collar so that the contact points are moved to a different spot on the dog's neck.

Proper e-collar use

dogtra e-collars are intended for the sole purpose of behavior modification of dogs. They are not intended for human use or use on other animals. Dogtra Company does not assume any liability for improper use of the Dogtra e-collar.

Aggressive dogs

dogtra does not recommend using the e-collar to correct dogs that are aggressive towards other dogs or people. In many such cases the dog will associate the stimulation with the other dog or individual and become even more aggressive. Dog aggression is best treated by a dog training specialist.

Interference with other electronic devices

Dogtra's industry-leading technology filtering system ensures minimal interference with other electronic devices (cellular phones, security systems, etc.). Our digital microprocessor offers thousands of unique codes to eliminate frequency match-up with other Dogtra e-collars.

Inadvertent activation

If the constant button is held down for 12 seconds or more the unit will automatically shut down. It will reactivate when the button is released.

***dogtra* COLLAR PACKAGE CONTENTS**

- Transmitter
- Receiver(s)
- Battery charger and splitter cable
- Test light
- Owner's manual
- Carrying case

DESCRIPTION OF TRANSMITTER PARTS

dogtra 1804NC transmitter

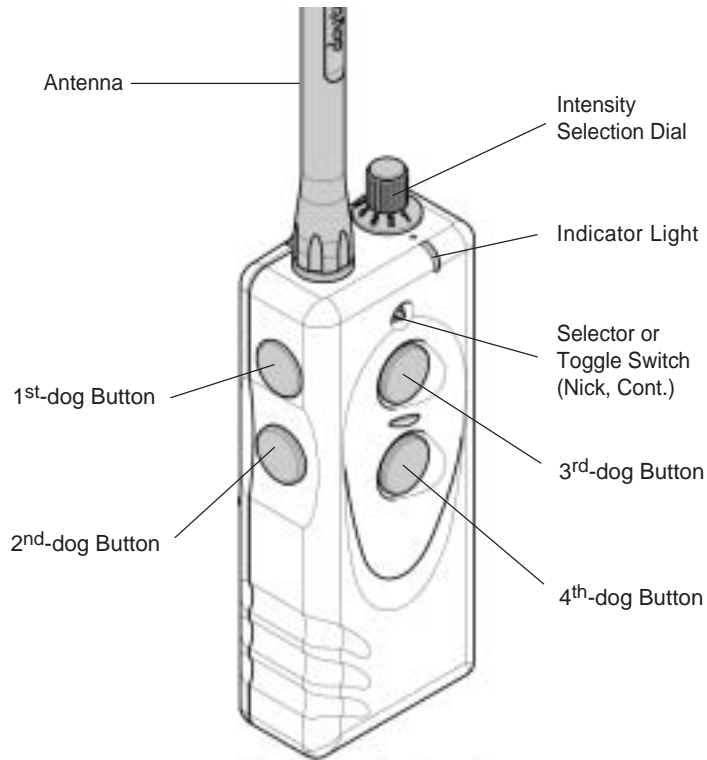

* indicates optional switch for 4-dog models

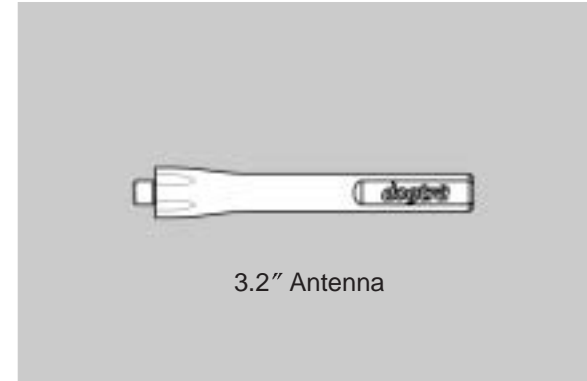

Transmitter Antenna

A heavy-duty 3.2" antenna is supplied with the *dogtra* 1800NC SERIES transmitter.

The antenna should be screwed into the top of the transmitter to ensure that the signals are sent properly to the collar receiver and that maximum range is attained.

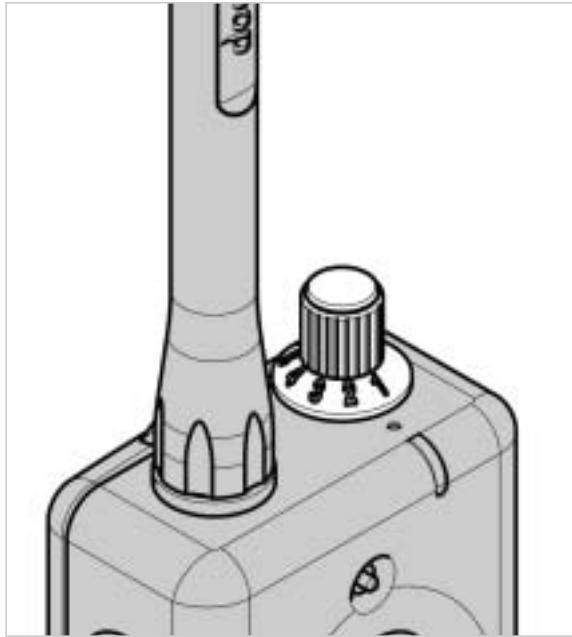

Intensity Selection Dial

The intensity selection dial is located on the top of the transmitter: (1) being the lowest level and (8) being the highest.

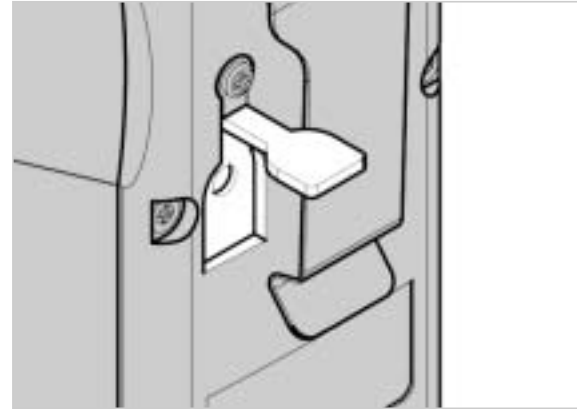

Transmitter Battery Charging Receptacle

Located on the side of the transmitter, the receptacle is covered by a rubber plug. Insert one end of the battery charging cable into the receptacle to charge the battery. (See Battery Charging Procedure on page 24.)

After charging is completed, close the receptacle with its rubber plug to make sure dirt or water does not get inside.

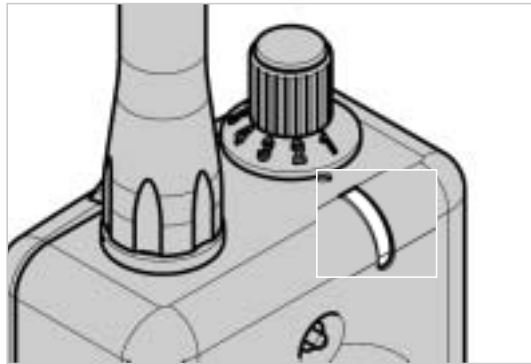

Transmitter Indicator Light (LED window)

The transmitter indicator light is located near the intensity selection dial. When a button on the transmitter is pushed, the light comes on to indicate that the transmitter is being activated. The color of the light indicates the status of battery life. The LED glows green when the battery is fully charged and turns to amber when battery life is getting low. When the LED emits a blinking red light, the battery needs to be recharged.

green = full charge, **amber** = medium charge
red = needs charge

BUTTON FUNCTION

***dogtra* 1800NC ONE-DOG MODELS**

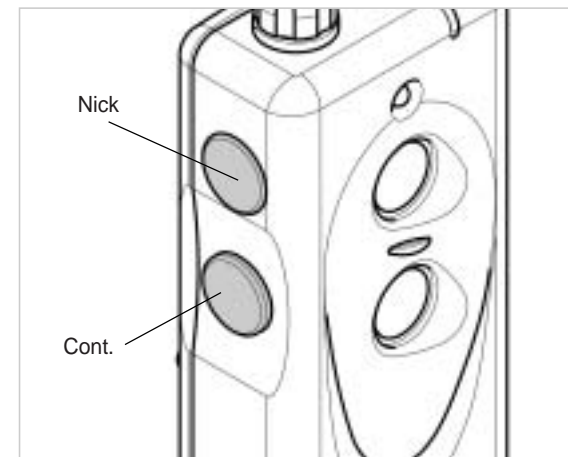

The transmitter for ***dogtra* 1800NC** has two buttons. The top is the Nick button and the bottom is the Constant button.

“Nick” Button

When the “Nick” button is pushed the receiver emits a single, rapid pulse of electrical stimulation.

“Constant” Button

Pressing the “Constant” button gives continuous stimulation as long as the button is pushed, for up to twelve seconds. If the button is not released after twelve seconds, the stimulation will automatically turn off as a safety feature. The collar will be ready to be reactivated once the button has been released.

dogtra 1802NC TWO-DOG MODELS

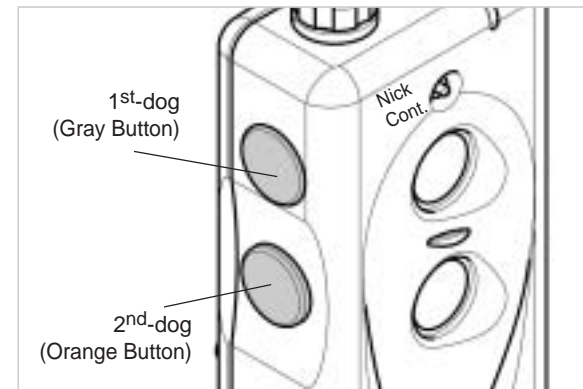

The transmitter for the *dogtra* 1802NC has two buttons; The 1802NC has two buttons on the side of the transmitter. The gray button corresponds to the receiver with the black collar strap and the orange button corresponds to the receiver with the orange collar strap. The toggle switch at the top of the transmitter allows you to choose between Nick and Constant type of stimulation.

***dogtra 1803NC* THREE-DOG MODELS**

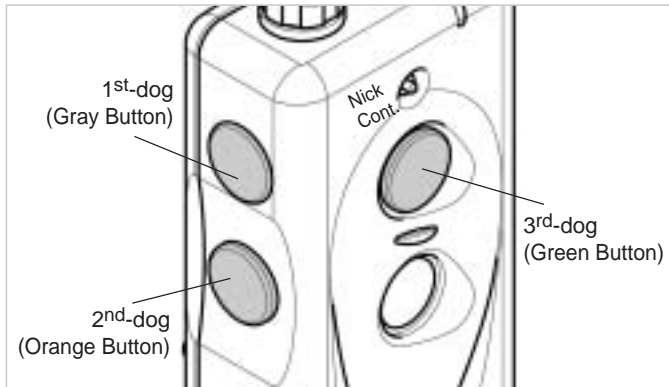

The transmitter for the *dogtra 1803NC* has three buttons; The Gray (1st dog) button corresponds to the receiver with the black collar strap. The Orange (2nd dog) button corresponds to the receiver with the orange collar strap. The Green (3rd dog) button corresponds to the receiver with the green collar strap.

The toggle switch at the top of the transmitter allows you to choose between Nick and Constant type of stimulation.

***dogtra 1804NC* FOUR-DOG MODELS**

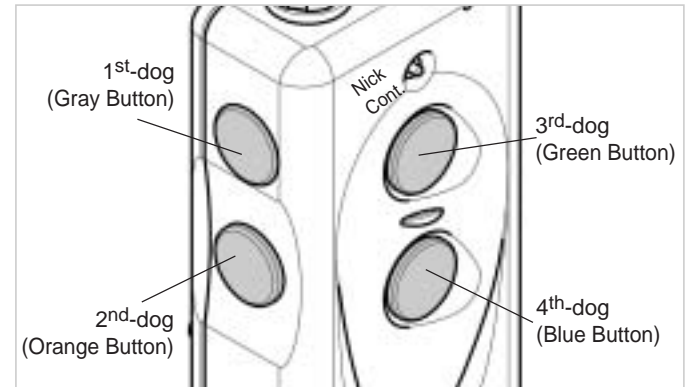

The transmitter for the *dogtra 1804NC* has four buttons; The Gray (1st dog) button corresponds to the receiver with the black collar strap. The Orange (2nd dog) button corresponds to the receiver with the orange collar strap. The Green (3rd dog) button corresponds to the receiver with the green collar strap. The Blue (4th dog) button corresponds to the receiver with the blue collar strap.

The toggle switch at the top of the transmitter allows you to choose between Nick and Constant type of stimulation.

DESCRIPTION OF COLLAR / RECEIVER PARTS

dogtra 1800NC SERIES collar

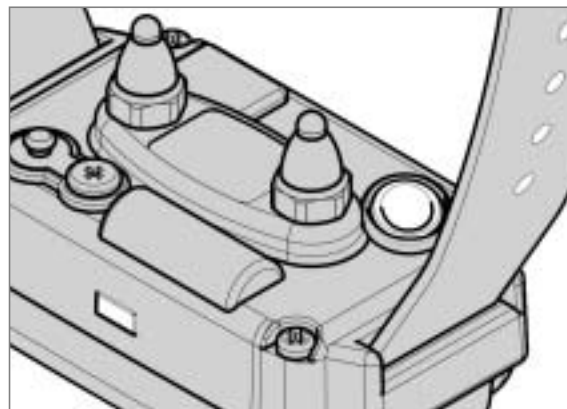
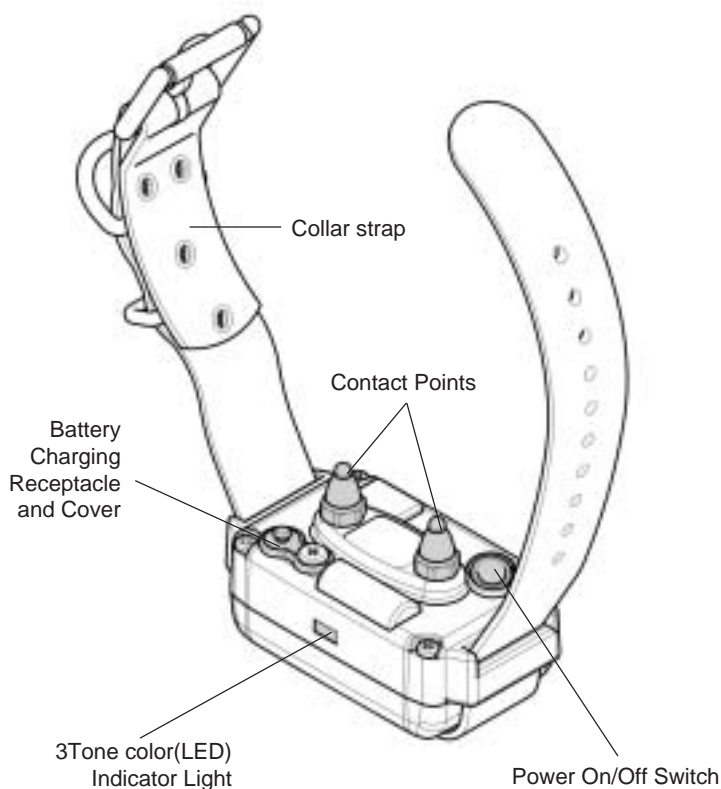

Turning on the Collar Receiver

The ON/OFF button is on the bottom of the receivers. Push and hold the button for two seconds until the LED light, located on the front of the collar, starts blinking. The indicator light will blink once every 2 seconds after the color is turned on. The color of the light indicates the status of battery life. The LED glows green when the battery is fully charged and turns to amber when battery life is getting low. When the LED emits a blinking red light, the battery needs to be recharged.

green = full charge, **amber** = medium charge
red = needs charge

When the “Constant” button on the transmitter is pushed, the collar indicator light will glow steadily as long as you hold the button down, for up to twelve seconds. When the “Nick” button is pushed, the light comes on for a fraction of a second.

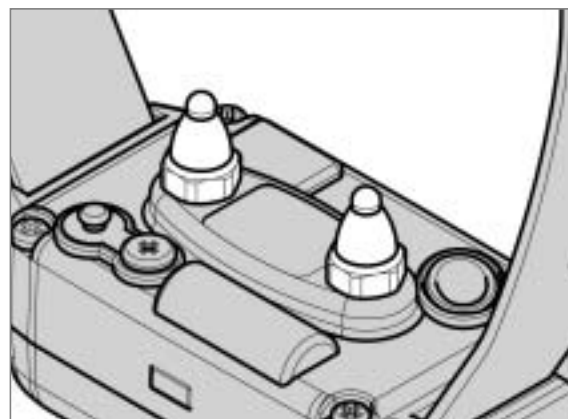

Fitting the Collar on the Dog

The collar should be fitted so that the stainless steel contact points press firmly against the dog’s skin.

A loose fit can allow the collar to move around on the dog’s neck. When this happens the contact points may rub the skin and cause irritation. If the collar is too loose, electrical contact will be inconsistent and your corrections will be inconsistent also.

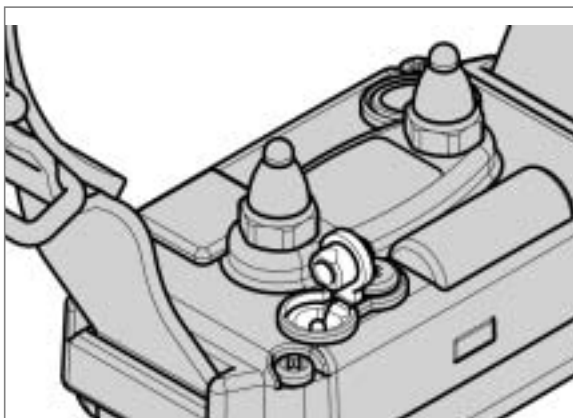

Receiver Battery Charging Receptacle

On the inside of the collar, next to the collar strap, is a battery charging receptacle with a rubber cover plug.

Internal Antenna

The **dogtra 1800NC SERIES** has a non-exposed antenna that is located inside the collar receiver.

BATTERY CHARGER

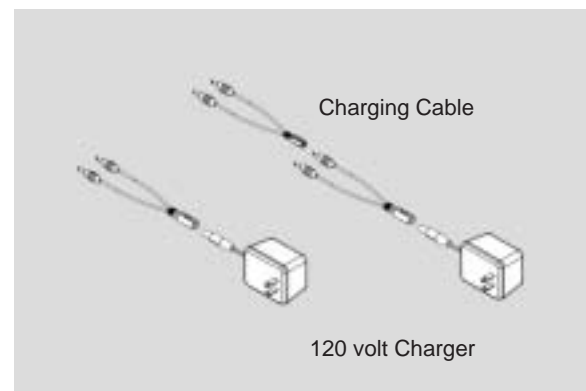

The battery charger and charging cables allow you to charge both the transmitter and receiver at the same time. The battery charger is designed for a 120-volt wall outlet. (European 230-volt AC chargers and 12-volt field charger for your automobile are also available.)

To use the battery charger for the a multiple-dog unit, combine additional sets of battery charging (splitter) cables as shown. This enables you to charge the transmitter and all receivers at the same time.

CHARGING THE BATTERIES

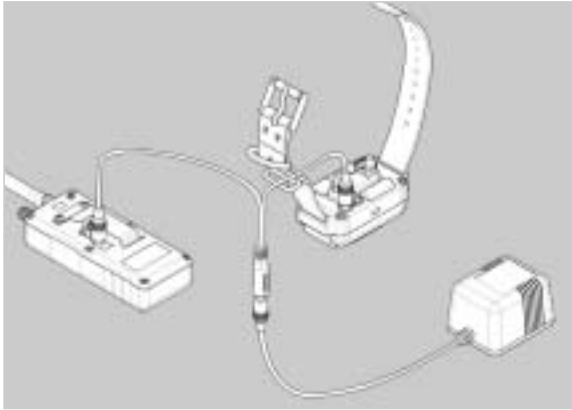

dogtra uses Ni-MH (Nickel-Metal-Hydride) batteries that do not set a memory and can be charged on a regular basis without harm to the battery. There is no need to completely drain the batteries between charges. However, doing so will help to extend the overall lifetime of the batteries.

1. Charge the batteries for 14 hours before using the collar for the first time.

2. Do not charge the batteries near any flammable substances.
3. Fully charge the batteries for 14 hours if the collar is to be stored without use for a period of a month or more.
4. Recharge the battery if :
 - the indicator light on the collar is emitting a red color
 - the indicator light on the transmitter or receiver will not come on
 - the indicator light on the transmitter or receiver comes on momentarily but will not stay on when the “Constant” button is pushed.In this case, charge the unit for a full 14 hours.

Battery Charging Procedure

1. Attach the charging cables to both the transmitter and receiver(s), as shown on page 22.
2. Plug the charger into a 120-volt wall outlet or, if using the accessory field charger, plug into a cigarette lighter. (Use a 230-volt European charger for Europe.) When properly plugged in, all indicator lights should glow red.

The receiver automatically turns off when you insert the charging cable into the battery charging receptacle on the receiver.

3. After charging, cover the battery charging receptacles with the rubber plugs on the transmitter and receiver.
4. The battery is fully charged with a 14-hour charge. The lights will stay red during the charging process. They DO NOT turn green when fully charged. Charging the batteries for more than 14 hours at one time will not extend battery life.

TESTING YOUR *dogtra* 1800NC SERIES COLLAR

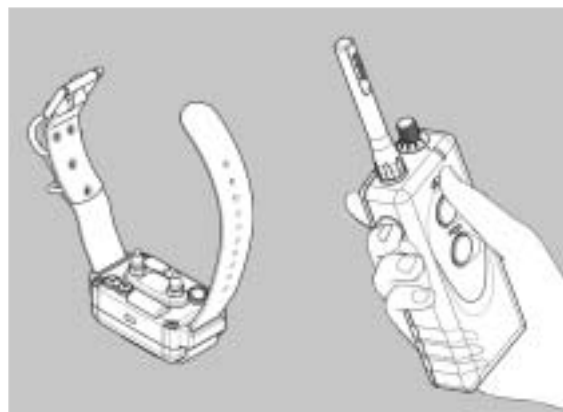

1. Turn the collar on by pressing the button on the back side of the collar receiver. The indicator light will come on for a moment then blink once every two seconds, showing that the collar is ready to use. (If the indicator light is red, the batteries need to be charged.) Place the test light on the contact points of receiver and hold it there.

2. Watch the test light as you push the “Nick” button on the transmitter. It should light for just a moment.
3. Watch the test light as you push the “Constant” button on the transmitter. It should glow brightly. As a safety feature, the collar receiver will automatically shut off stimulation if the constant button is depressed for twelve seconds or longer.
4. Change the intensity dial on the transmitter clockwise and then counterclockwise. The test light should glow brighter with higher levels of stimulation and dimmer with lower levels.

NOTE : It is normal for the test light not to come on if the intensity level is set below level ten.

5. Pressing the “Pager” button on the side of the transmitter causes the collar to vibrate for up to twelve seconds. The collar will reactivate when you push the button again.

OPERATING INSTRUCTIONS

Fitting the Collar

The collar strap should be adjusted so that the contact points are held firmly against the dog’s skin. If the collar is too loose, irritation may result from the contact points rubbing against the skin.

If the dog has a heavy coat, move the receiver up and down to work the contact points down into the coat.

ATTENTION!

Avoid having the dog wear the collar with the contact points in the same place for more than two hours at a time. Leaving the points on the same spot for extended periods of time can cause skin irritation. If the dog is to wear the e-collar for long periods, occasionally reposition the collar so that the contact points are moved to a different spot on the dog’s neck.

Intensity Selection

To select the intensity level, start on the lowest (1) setting. Gradually increase the level until you get a response from the dog that would be equivalent to a quick pull or jerk with a leash.

Remember that you will need to adjust the setting (upward or downward) as the dog's attitude changes, especially during times of increased excitement or distraction.

Maintenance

The receiver and collar strap should be cleaned periodically with detergent and water to prevent malfunction.

Always clean and rinse the collar thoroughly with tap water after use in salt water. Be sure the charging receptacle is completely dry before inserting the battery charger into the transmitter or receiver.

Reception

The **dogtra 1800NC SERIES** collar has one-mile range. Depending on the way you use your transmitter, the transmitting range may vary.

Hold the transmitter away from your body and avoid touching the antenna to get the greatest range.

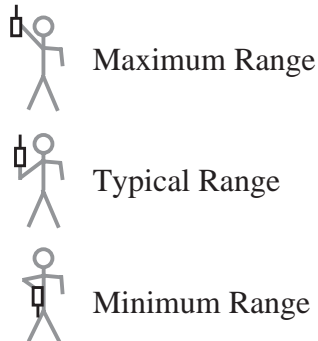

If your finger touches the antenna near the dial on the top of the transmitter, the actual range may be reduced. Additional environmental factors may also affect the range of your unit.

ACCESSORIES

The following items may be purchased separately :

European Charger

Designed for use with 230V AC electrical outlets in Europe.

Field Auto Charger

Designed for use with the 12-volt cigarette lighter in your car.

WARRANTY AND REPAIR INFORMATION

Dogtra Company provides the original purchaser with a **LIMITED LIFETIME WARRANTY**. Limited Lifetime Warranty begins from the date of purchase. For the first two years coverage is for both parts and labor, on all our products purchased new. Accessories such as, chargers, splitter cables, antennas, straps and **batteries** have a one-year warranty from the date of purchase. Once the first and second year warranty coverage expires, the Limited Lifetime Warranty will cover for all parts except accessories and labor fees. Labor fees and shipping fees incurred are the customers' responsibility. Labor fees will be variable depending on the extent of work required. The Limited Lifetime Warranty will expire 5 years from the date a model is discontinued in production by Dogtra Company.

To Qualify for the Limited Lifetime Warranty :

To register your Dogtra product, please log onto our website at www.dogtra.com, click on the warranty registration link and fill out the required information. All registration must be completed within 30 days of your purchase. If you do not have access to a computer, you can call our toll free number of 888-811-9111 so one of our customer service representatives can register your product online for you. Also if you were unable to register your product on our website we will accept all products for repair with a proof of purchase. We strongly recommend you keep your original receipt. If your product is not registered and proof of purchase is not available at the time of service, Dogtra will estimate the age of the unit by the serial number. Serial number estimates can be different than the actual purchase time. Without proof of purchase or product registration this is the only method we have for determining the approximate date of purchase.

Not Covered Under Warranty :

We cannot offer warranty for units/products that have been bought secondhand or as a resold product.

Dogtra **DOES NOT** replace defective units or provide refunds for products purchased from us after 30 days from the date of the purchase. Issues of replacement and refunds on units purchased less than 30 days from an authorized dealer need to be addressed to the dealer directly.

Dogtra's warranty **DOES NOT** cover repairs or replacements due to misuse by the owner or dog, improper maintenance, and/or lost units. Any water damage on the Water Resistant Transmitters of the 175NCP, 180NCP, 200NCP, 202NCP, 1400NCP, 1402NCP, 1500NCP and 1502NCP will also not be covered. All replacement cost for either the transmitter or receiver will be the owner's responsibility.

*** Battery replacement by the customer during the first year of the warranty is not recommended. If the customer chooses to replace the batteries, any damage to the unit during the change-out by the owner will void the warranty.**

The warranty is void if the unit has been altered or an unauthorized person has attempted repair work.

Procedure for Repair Work :

The cost of shipping products under warranty back to Dogtra is the customer's responsibility. Dogtra will provide/pay (via regular ground service, within the continental United States) the shipping cost back to the customer. Any expedited shipping service will be at the customer's expense. Dogtra is not responsible for loss of training time or inconvenience while the unit is in for repair work. **Dogtra does not provide loaner units or any form of compensation during the repair period.**

WARRANTY

A copy of the sales receipt showing the purchase date is required before warranty work is initiated.

Please include a brief explanation outlining the problems and include your name, address, city/state/zip code, **daytime phone number, evening phone number, and email address.** Or, you can visit our website at www.dogtra.com. Click on the Service Request Form, print it out and follow the instructions.

If repair costs are not covered under warranty, we will call you for credit card information once the work has been completed. For any questions concerning your Dogtra products call us Toll Free at 1-888-811-9111, M-F 8:30AM - 4:00PM, Pacific Time, or email us at repair@dogtra.com for specific repair inquiries.

Send repair units to:

Dogtra Company / Repairs

22912 Lockness Avenue
Torrance, CA 90501
U.S.A.